

Evolution Stainless Steel

QUICK START GUIDE



Specification

EVO-12-SS2	
Resolution	12MP
Power Input	12 VDC, 1.0 A (min) LPS, NEC Class 2 power supply
	Power over Ethernet (PoE), IEEE standard 802.3af
Ratings	IP66, IP67, IP68 (2m 30min), IP69K, NEMA 4X, 6P, IK10+
Operating Temperature	-40°C to 55°C (-40 °F to +131°F)
Enclosure	Electropolished marine grade 316 stainless steel with polymer bubble
Weight	5.11 kg (11.27 lbs)

Important



Read these instructions carefully before installing or operating this camera.

This camera should be installed by a qualified service person and the installation should conform to local and national regulations.

The camera should be installed with the weight in mind, installation via access platform is recommended.

Fixing used should be of appropriate strength and suitable for use around stainless steel.

Chloride from cleaning products will cause the stainless steel to loose chrome content and therefore corrode.

Chlorine from poorly managed swimming pools can also become Chloride.

This camera is not suitable for installation in a ceiling void that is used as an air handling space.

Certified as FCC Class A. In a domestic environment this camera may cause radio interference in which case the user should take adequate measures.

Placing this enclosure on or near ferrous material will cause the product to become stained and to collect corrosion over time.

For best results the stainless steel should be cleaned regularly with a lint free cloth and sunflower oil or equivalent. Care should be taken not to get the oil on the dome.



DANGER: RISK OF EXPLOSION IF REPLACING A BATTERY WITH AN INCORRECT BATTERY TYPE.



Please ensure you have the correct mounting accessories and fittings before proceeding with your installation.

1. Contents



1. Contents	3
2. Box Contents	3
3. Disassemble the Camera Enclosure	4
4. Mounting Options	5
5. Surface Mounting	6
6. Surface Mount with Conduit Adaptor	9
7. Pendant Mount Adaptor	14
8. Environmental Shield	14
9. Attach to Pendant	15
10. Start-up	19
11. Cleaning and Maintenance	22

2. Box Contents

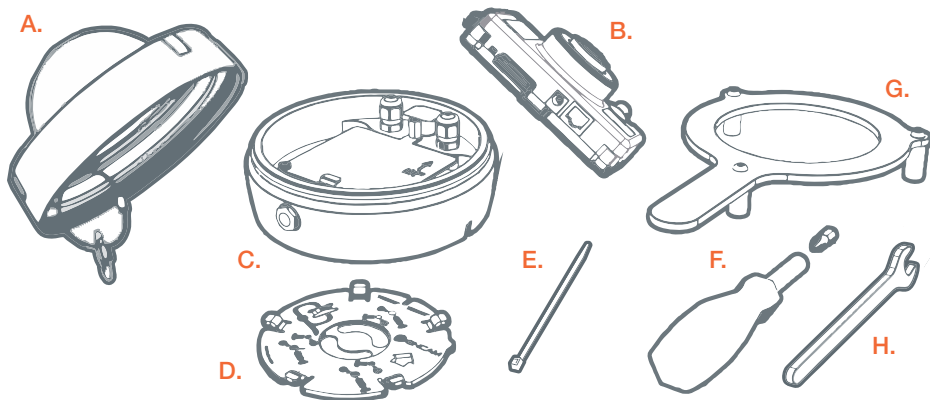

- | | | | |
|----|----------------|----|-----------------------|
| A. | Dome Cover | E. | Cable Tie |
| B. | Camera Module | F. | Driver and Bit |
| C. | Rear Enclosure | G. | Security Locking Tool |
| D. | Mounting Plate | H. | Spanner |

The Evolution Stainless Steel Camera is designed for installations on flat surfaces, pendants or corners. Conduit Adaptor, Pendant Adaptor, Pole and Corner Mount accessories, and Pendant Arm are sold separately.



Make a note of the camera's MAC address and installation location. Find the MAC address printed on the camera label.

3. Disassemble the Camera Enclosure



Do not remove the Protective Film from the Dome

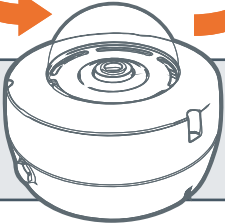

3.1 Unscrew the Dome Cover, taking care not to touch the Dome.

3.2 Whilst holding the Dome Cover unscrew the nut then unhook the Lanyard. Do NOT remove the Protective Film from the Camera Module Lens.

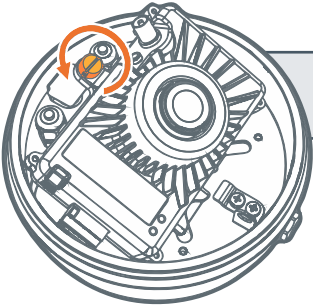
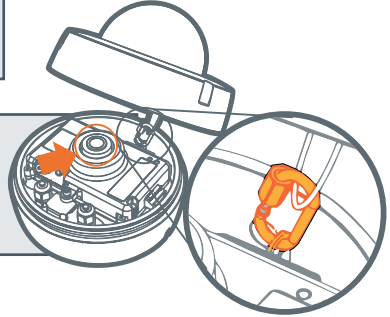

3.3 Undo the Camera Module Thumb Screw and remove the Camera Module.

3.4 Lifting the Yellow Warning Label up expose the Locking Pin. Unscrew until the loose.

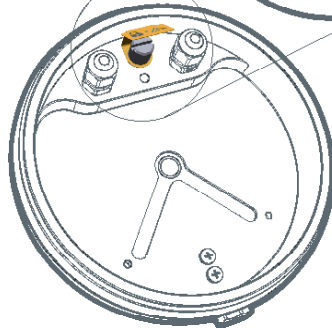
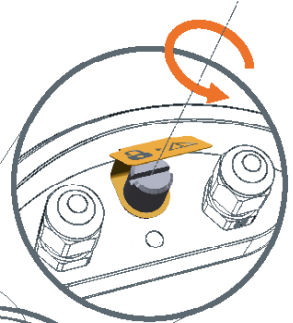

3.5 Twist and lift the Mounting Plate away from the Rear Enclosure.

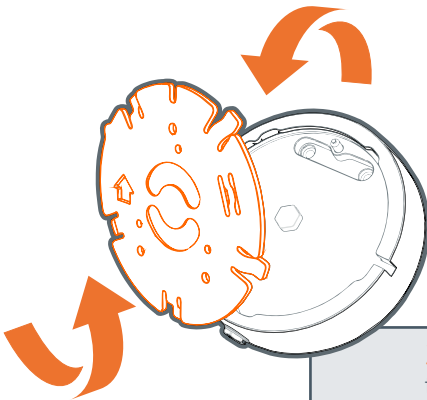

4. Mounting Options

Surface Mounting go to
Section 5 on Page 6



Surface Mount with Conduit
Adaptor go to Section 6 on
Page 9

Pendant Mount Adaptor go to
Section 7 on Page 14



5. Surface Mounting

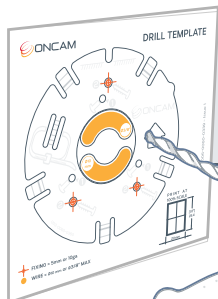

5.1 Using the Drilling Template, drill the three mounting holes for appropriate fixings. Drill an appropriate hole for the Ethernet Cable in the **YELLOW** area. Max. diameter 10mm [3/8"].

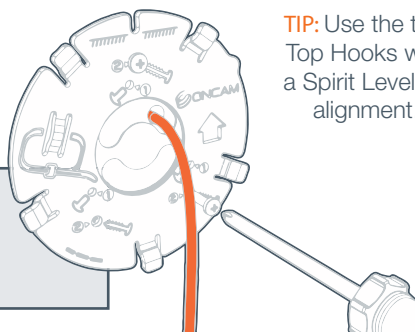
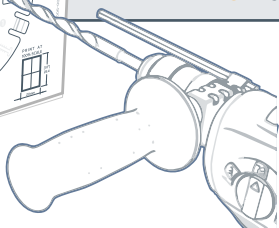

TIP: Use the two Top Hooks with a Spirit Level for alignment.

5.2 Feed 60cm [24in] of the Ethernet Cable through the Mounting Plate and fix to the wall using appropriate fixings designed to work with stainless steel.



5.3 Wrap Ethernet Cable around and hold it in place using the supplied Cable Tie. Please only use the Cable Tie provided.

30cm [12in]

5.4 Pull 30cm [12in] of the unterminated Ethernet Cable through one Gland, having removed its Blanking Plug.

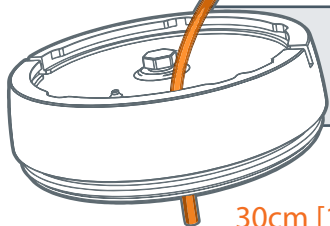

30cm [12in]

5.5 Using the hooks for alignment hang the Rear Enclosure onto the Mounting Plate, turn clockwise until it stops hard.

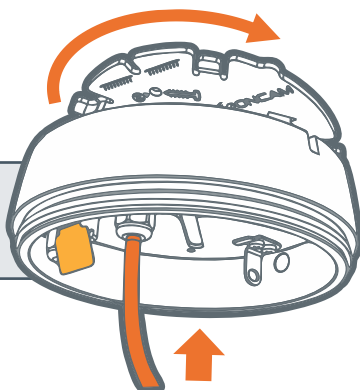

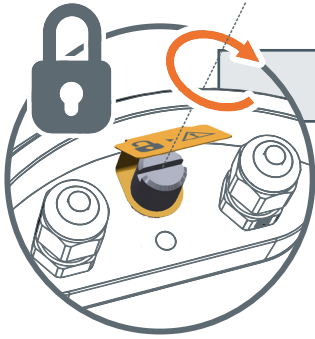

5.6 Re-tighten the Locking Pin.



Failure to tighten the Locking Pin correctly may lead to the Assembled Camera falling.

5.7 Tighten the Glands, ensure they are ALL closed properly.

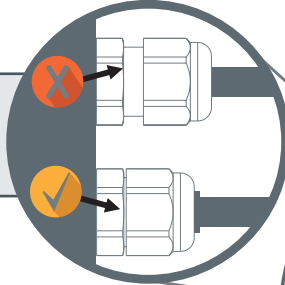

Failure to ensure ALL of the Glands on the Assembly are correctly tightened may lead to water ingress.

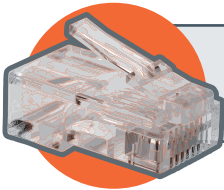
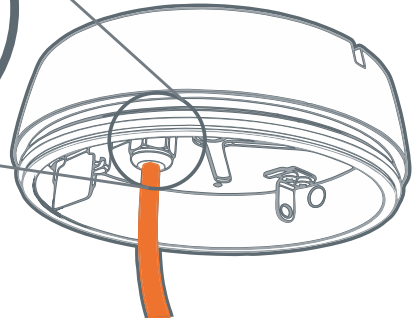

5.8 Terminate the Ethernet Cable using an RJ45 plug, connect to the Camera Module.

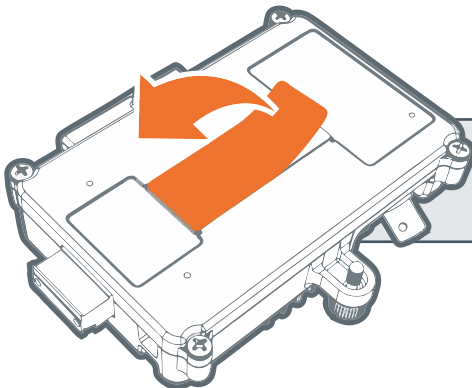

5.9 Remove the protective film from the Heat Transfer Pad on the bottom of the Camera Module.

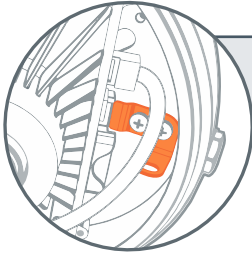

5.10 Insert the Camera Module inside the Rear Enclosure hooking it into place.

5.11 Secure the Camera Module in place using the retaining Thumb Screw.

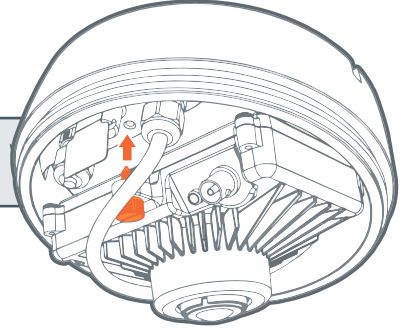

5.12 Lay the Ethernet Cable around the Camera Module.

5.13 Both Camera Module LEDs should be solid green when the camera is booted with a powered Ethernet connection.

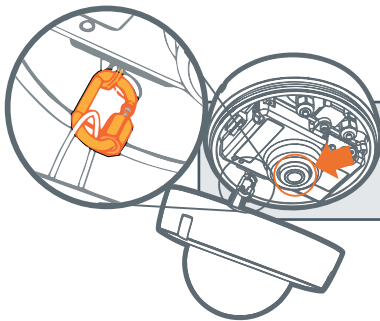
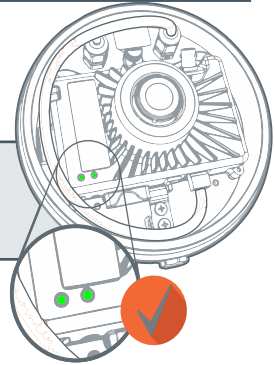

5.14 Reattach the Lanyard to the Mounting Clip, ensure nut is tight. Remove the Protective Film from the Lens.



NOTE: When attaching the Lanyard, failure to ensure the nut is tight may result in the Dome Cover falling during the installation or routine maintenance.

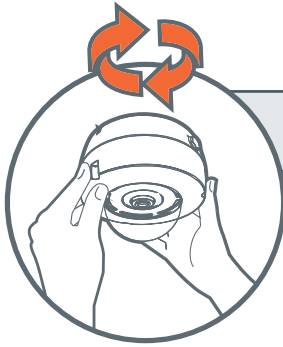

5.15 Screw the Dome Cover on by hand before using the Security Locking Tool.

5.16 Use the Security Locking Tool to tighten fully.

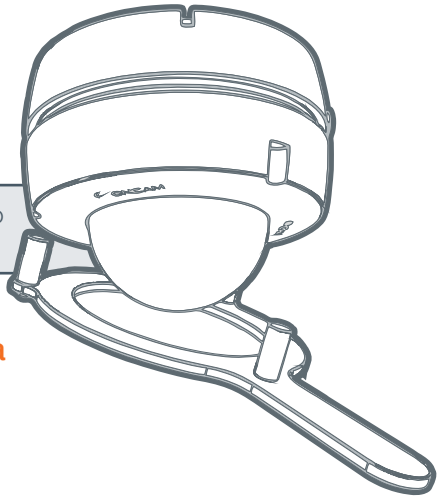

First use of the camera

Please refer to Step 10 on page 19

6. Surface Mount with Conduit Adaptor

Box Contents - OBE-20-SCA - Sold Separately

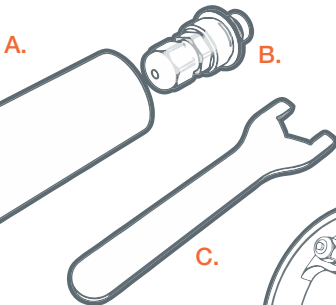

- A. Conduit Sleeve
- B. Threaded Gland Assembly
- C. Slim Spanner

TIP The Conduit Entry is in the direction of the bottom of the camera image.

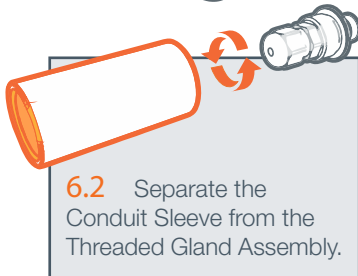

6.2 Separate the Conduit Sleeve from the Threaded Gland Assembly.

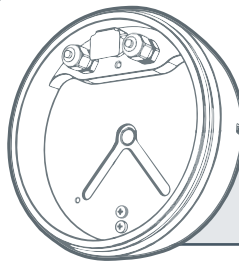

6.1 Unscrew the Blanking Plug at the bottom of the Rear Enclosure.



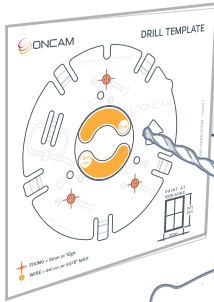

6.3 Using the Drilling Template, drill the three mounting holes for appropriate fixings.

TIP: Use the two Top Hooks with a Spirit Level for alignment.

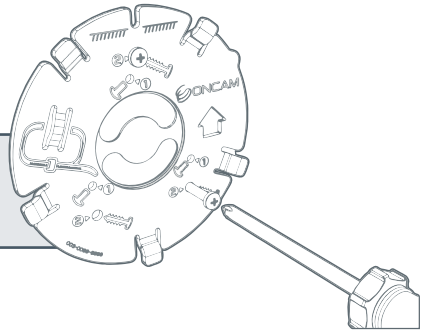
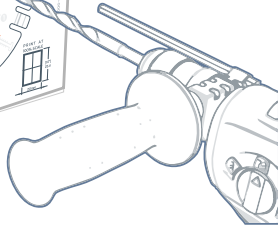

6.4 Screw Mounting Plate to the wall using appropriate fixings designed to work with stainless steel.

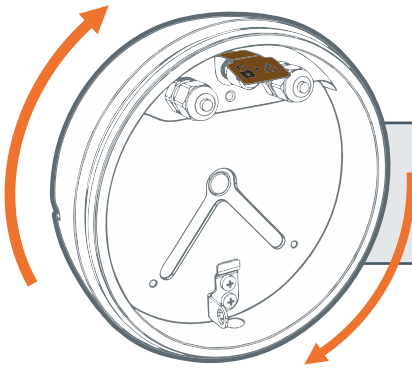

6.5 Using the hooks for alignment hang the Rear Enclosure onto the Mounting Plate, turn clockwise until it stops hard.

6.6 Re-tighten the Locking Pin.

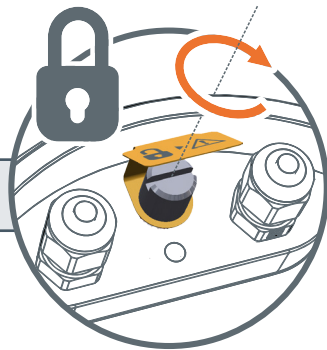

Failure to tighten the Locking Pin correctly may lead to the Assembled Camera falling.

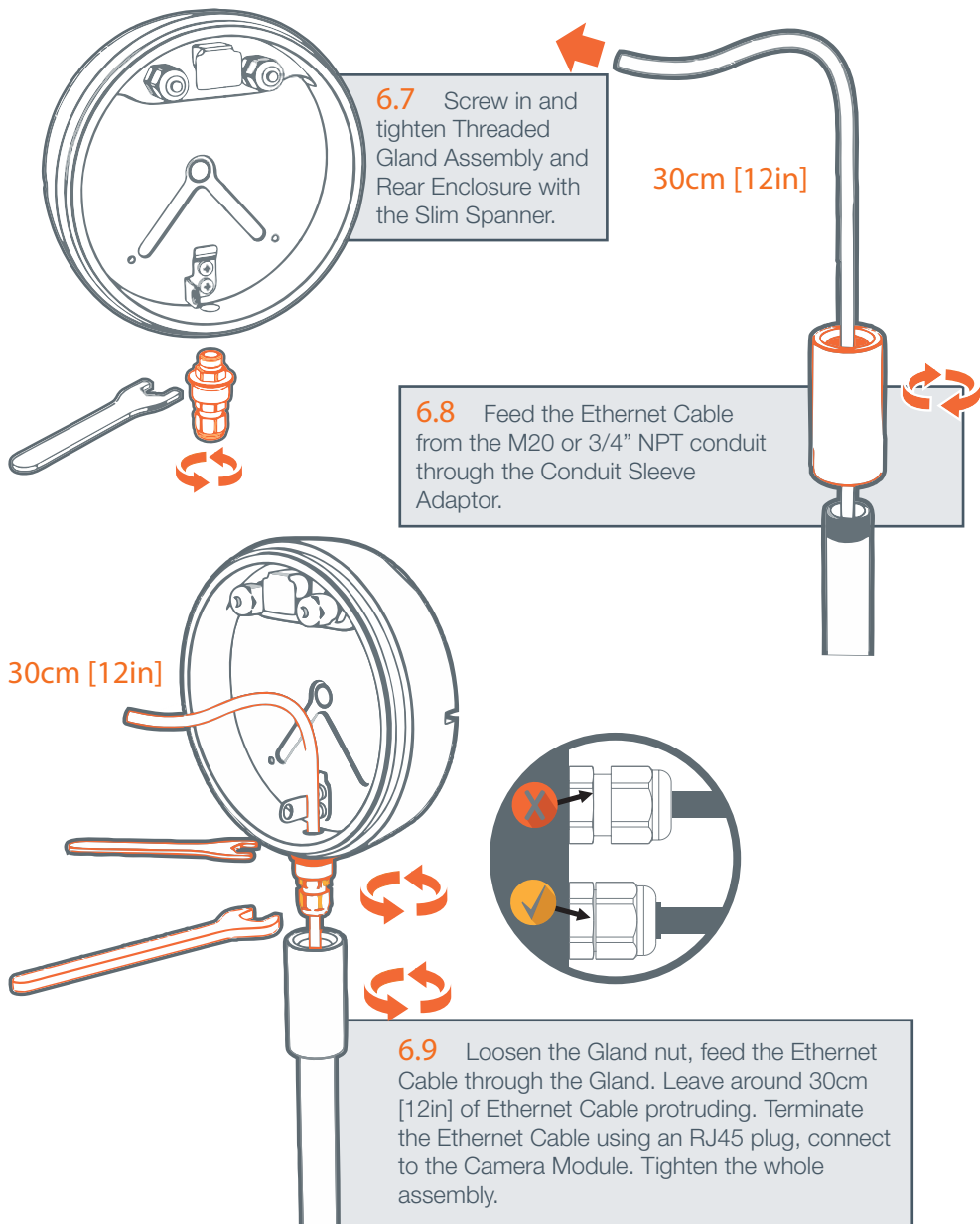

Failure to ensure ALL of the Glands on the Assembly are correctly tightened may lead to water ingress.

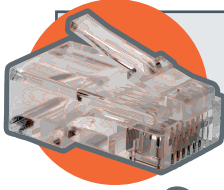

6.10 Terminate the Ethernet Cable using an RJ45 plug, connect to the Camera Module.

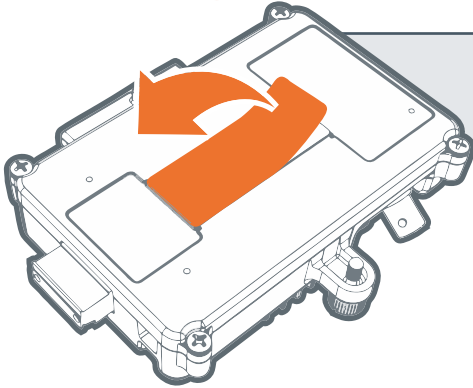

6.11 Remove the protective film from the Heat Transfer Pad on the bottom of the Camera Module.

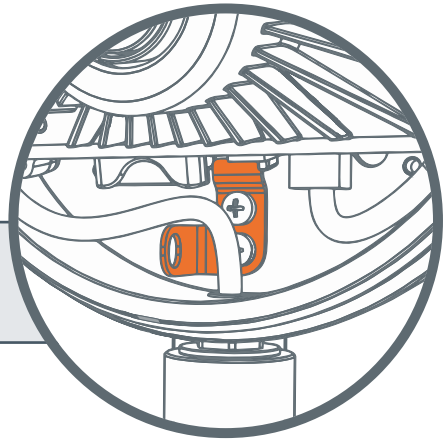

6.12 Insert the Camera Module inside the Rear Enclosure hooking it into place.

6.13 Secure the Camera Module in place using the retaining Thumb Screw.

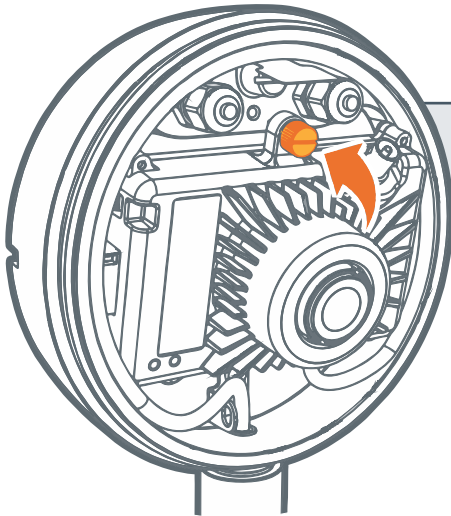

6.14 Lay the Ethernet Cable around the Camera Module.

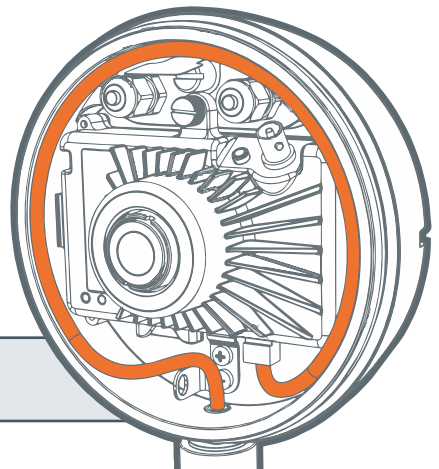

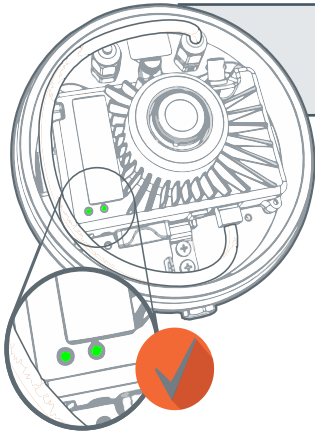

6.15 Both Camera Module LEDs should be solid green when the camera is booted with a powered Ethernet connection.

6.16 Reattach the Lanyard to the Mounting Clip, ensure nut is tight. Remove the Protective Film from the Lens.

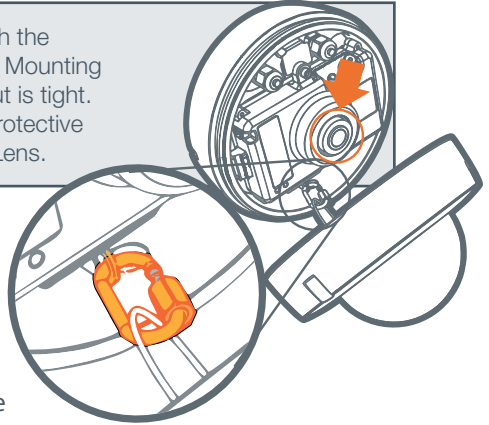

NOTE: When attaching the Lanyard, failure to ensure the nut is tight may result in the Dome Cover falling during the installation or routine maintenance.

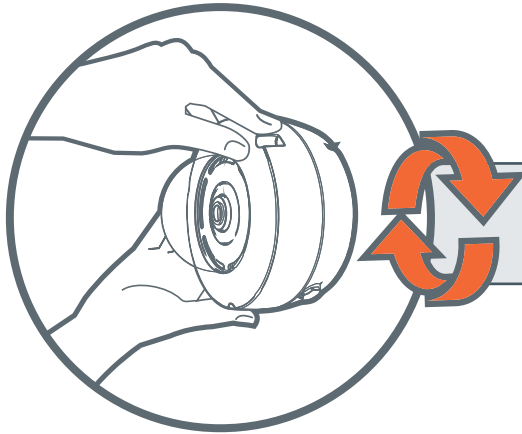

6.17 Screw the Dome Cover on by hand before using the Security Locking Tool.

6.18 Use the Security Locking Tool to tighten fully.

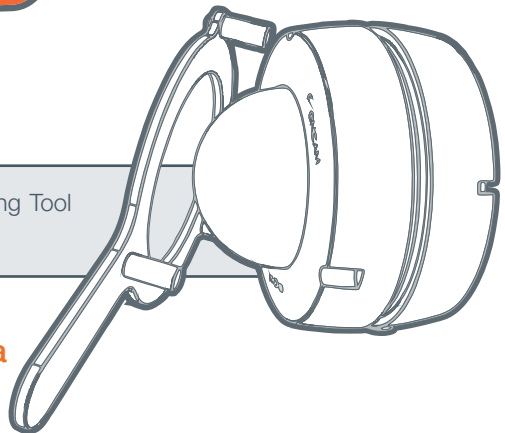

First use of the camera

Please refer to Step 10 on page 19

7. Pendant Mount Adaptor

Box Contents - OBE-20-SPM - Sold Separately

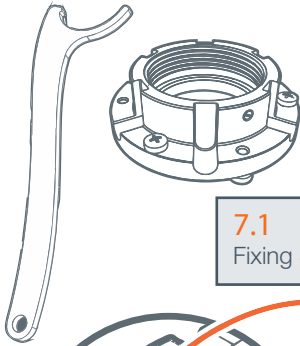

- A. Pendant Mount Adaptor
- B. Fixing Screws
- C. Hook Spanner

7.1 Remove the bottom three Fixing Screws only.

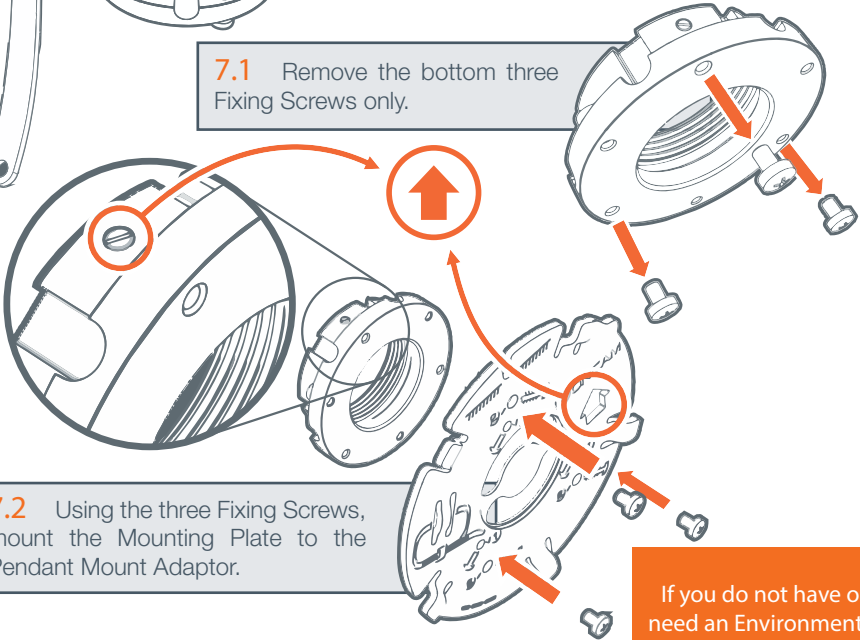

7.2 Using the three Fixing Screws, mount the Mounting Plate to the Pendant Mount Adaptor.

If you do not have or need an Environmental Shield skip Step 8

8. Environmental Shield

Box Contents - OBE-20-SES - Sold Separately

- A. Environmental Shield

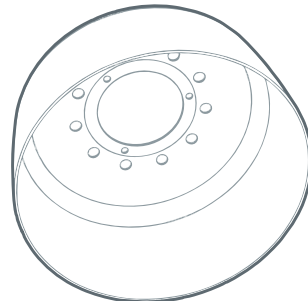

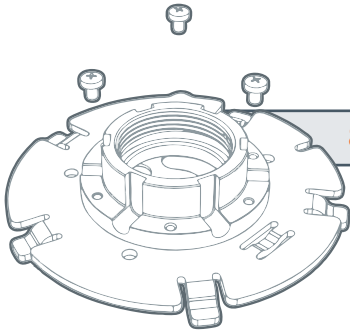

8.1 Remove the top three Fixing Screws.

8.2 Add the Environmental Shield and screw it to the Pendant Mount Adaptor.

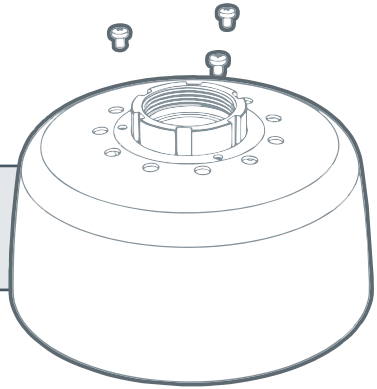

9. Attach to Pendant

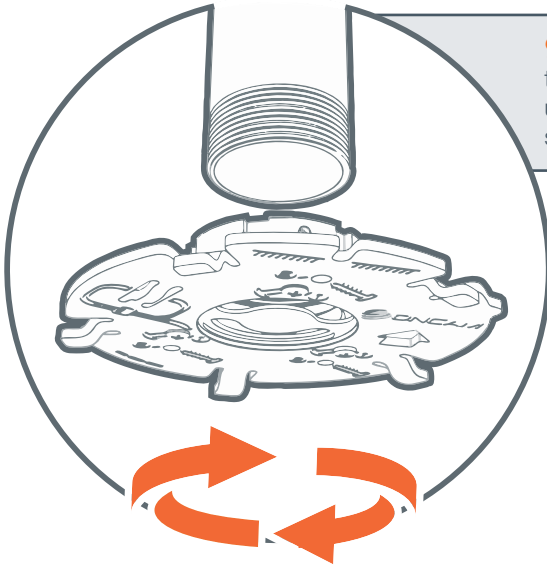

9.1 Screw the Assembly onto the 1 1/2" NPT Threaded Conduit until it stops and then unscrew to set the camera direction.

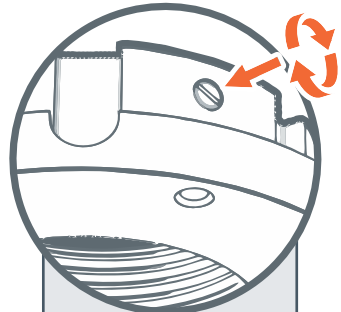

9.2 To lock the assembly in place tighten the Grub Screw.

Tip: The Locking Screw is in the direction of the top of the Camera image.



Failure to use Locking Grub Screw allows the camera to be undone and may fall.

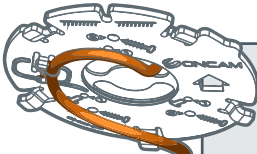

30cm [12in]

9.3 Wrap Ethernet Cable around and hold it in place using the supplied Cable Tie. Please only use the Cable Tie provided.

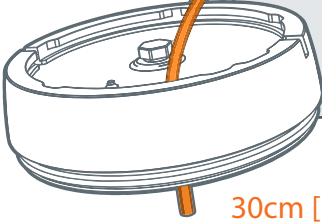

30cm [12in]

9.4 Pull 30cm [12in] of the unterminated Ethernet Cable through one Gland, having removed its Blanking Plug.

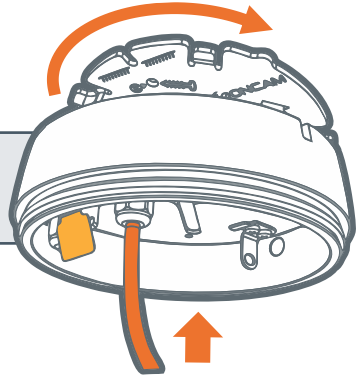

9.5 Using the hooks for alignment hang the Rear Enclosure onto the Mounting Plate, turn clockwise until it stops hard.

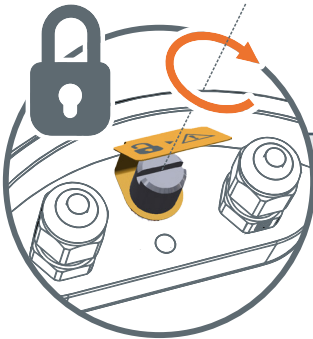

9.6 Re-tighten the Locking Pin.



Failure to tighten the Locking Pin correctly may lead to the Assembled Camera falling.

9.7 Tighten the Glands, ensure they are ALL closed properly.

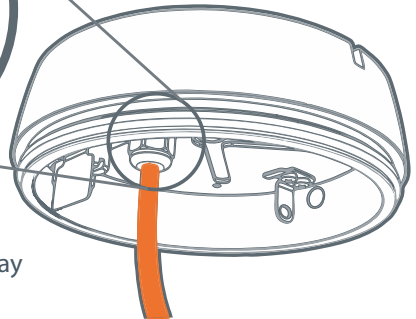
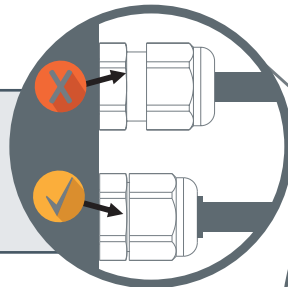

Failure to ensure ALL of the Glands on the Assembly are correctly tightened may lead to water ingress.

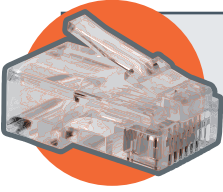

9.8 Terminate the Ethernet Cable using an RJ45 plug, connect to the Camera Module.

9.9 Remove the protective film from the Heat Transfer Pad on the bottom of the Camera Module

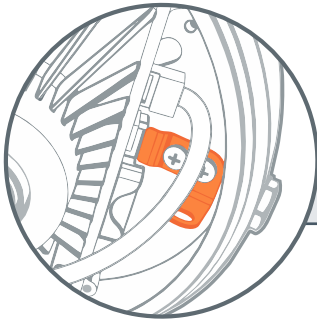
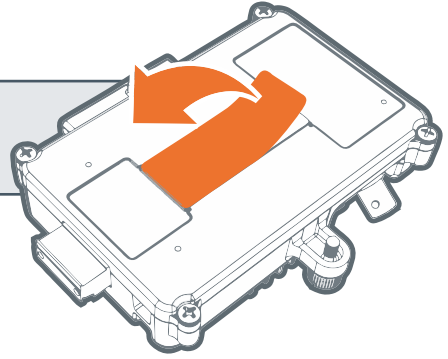

9.10 Insert the Camera Module inside the Rear Enclosure hooking it into place.

9.11 Secure the Camera Module in place using the retaining Thumb Screw.

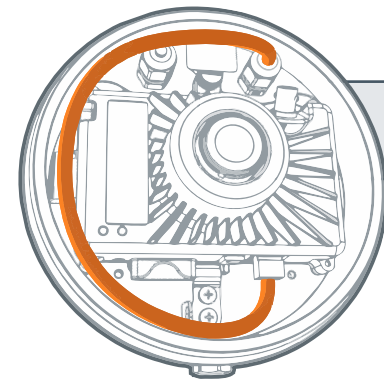
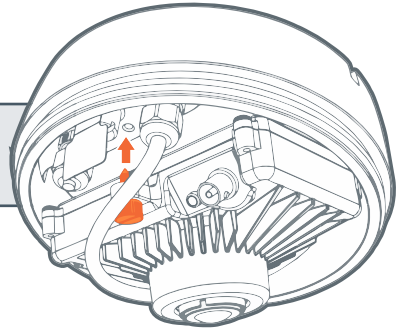

9.12 Lay the Ethernet Cable around the Camera Module.

9.13 Both Camera Module LEDs should be solid green when the camera is booted with a powered Ethernet connection.

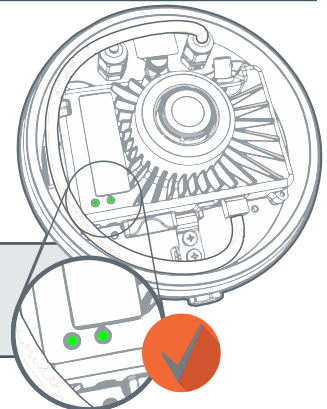

9.14 Reattach the Lanyard to the Mounting Clip, ensure nut is tight. Remove the Protective Film from the Lens.

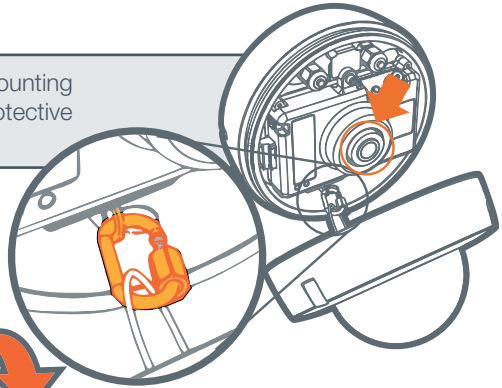
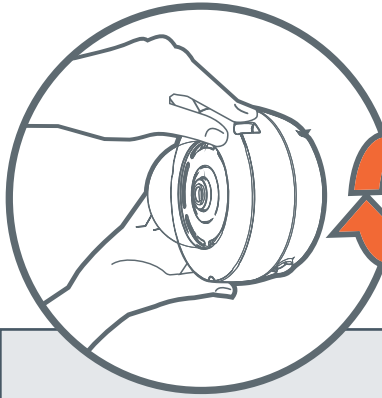

NOTE: When attaching the Lanyard, failure to ensure the nut is tight may result in the Dome Cover falling during the installation or routine maintenance.



9.15 Screw the Dome Cover on by hand before using the Security Locking Tool.

9.16 Use the Security Locking Tool to tighten fully.

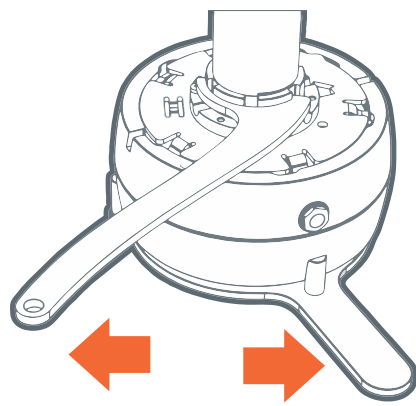
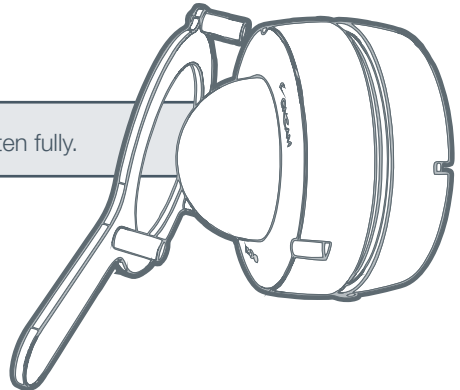

TIP: To counter the torque from the locking tool, use the Hook Spanner on the Pendant Mount Adaptor to hold it in place.



First use of the camera

Please refer to Step 10 on page 19

10. Start-up

10.1 Powering the Camera

Supply power to the camera with PoE IEEE802.3af through the integrated RJ45 Ethernet port or using the 12V DC input pins on the I/O connector. (Do not use both power sources at the same time). Both camera LEDs will be green when the camera is booted with an Ethernet connection.

10.2 IP Settings

In order to use the camera you will need its IP address.

There are two IP modes:

- DHCP
- Static IP (Default static IP is: **192.168.0.200**)

Should a DHCP server not be available, the camera adopts the default static IP address above.

There are 2 methods for accessing the camera stream, either through the Configuration Tool or via a Browser if the camera's IP address is known.

Note: See the camera's User Manual and Camera Configuration Tool User Manual for IP Setting adjustments.

10.3 Using the Camera Configuration Tool

The Camera Configuration tool quickly finds the IP and MAC addresses of all Oncam Evolution Cameras connected to the network. It also allows you to change network settings, configure multiple cameras and perform software updates.

Go to the Oncam website (<https://www.oncamgrandeye.com/resources/camera-config-tool/>) to download the latest version of the Camera Configuration tool and

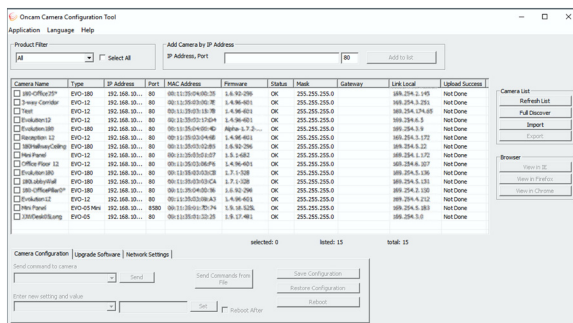

its User Manual.

Start the application, and the software will scan the network and provide a list of all connected Oncam Evolution cameras, as shown.

Note: Some functions in this tool require a username and password. If accessing the camera for the first

time, an administrator username and password will need to be set.

10.4 First Time Camera Access

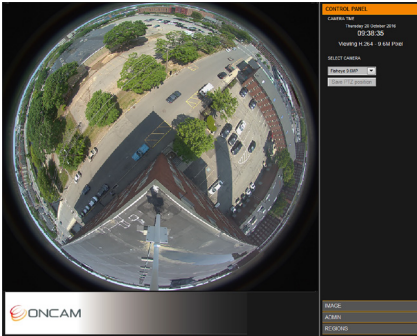

Web Browser

1. If you know the IP address of the camera, enter this into the address bar of your web browser (Internet Explorer, Edge, Firefox or Chrome). The camera should be on the same network.
2. Create an Admin username and password.

Notes:

Internet Explorer 11 is required to view live camera images in the browser. All other browsers can be used for Configuration Purposes only.

Ensure you have the latest [VLC Media Player](http://www.videolan.org/vlc/index.html) (<http://www.videolan.org/vlc/index.html>) for viewing camera images on the web interface.

Camera Configuration Tool

1. Select a camera from the camera list
2. Select your browser to open the web interface.
3. Click OK on the authentication pop up. You will then be prompted to create and set an Admin username and password to access the camera.

10.5 Technical Support

For the Datasheet, A&E Specification, Installation and User Manual, Software and Firmware visit:

<https://www.oncamgrandeye.com/resources/product-downloads/>

Tel: UK +44 (0) 20 7371 6640

US +1 978 735 4860

Email: support@oncamgrandeye.com

10.6 Mac Address



Make a note of the camera's MAC address and installation location. Find the MAC address printed on the camera label. This information may be needed during the camera configuration.

10.7 Next Steps

Download our FREE ONVU360 Pro mobile application and put the 360-degree experience right at your fingertips.



Copyright 2020 by ONVU Technologies AG. All rights reserved. Oncam is a trading name of ONVU Technologies AG. Subject to change without notice. All screen images are simulated. Specifications and configurations subject to change without notice.

Legal Notice: Parts of this product are protected by patents.



Stainless steel is an alloy of iron containing a minimum of 10.5% Chromium, which is resistant to tarnishing and rust.

When exposed to oxygen in the air, Chromium produces a thin layer of oxide on the surface of the steel known as the 'passive layer'. This prevents any further corrosion of the surface. Increasing the amount of Chromium gives an increased resistance to corrosion.

Oncam use 316 for the enclosure of the Evolution Stainless steel camera and it has 16% chromium content, which provides a higher degree of protection against the elements.

Many materials can have a negative effect on Stainless Steel by reducing the amount of Chromium in the stainless steel and therefore its protection. The three worst offenders are:

- Free Iron from steel tools, steel fixings and surrounding steel structures dilutes the percentage of chromium to below 11% and allows rust to form.
- Free Carbon reacts with the Chromium to form Chromium Carbides, which actively strip the Chromium from stainless steel and prevent the passive layer from being formed.
- Chloride found in many cleaning agents also negatively react with the Chromium, which can lead to aggressive corrosion.

The best way to keep the Evolution Stainless Steel camera enclosure looking its best, is to limit the exposure to Free Iron, Free Carbon, Chlorides and other materials that may affect the Chromium.

Depending on the environment, regular cleaning is recommended:

- Remove any dirt from the camera enclosure using a lint free cloth
- A mild degreaser like white vinegar is suggested; rinse thoroughly with plain water, as this should allow the Chromium Oxide to reform.
- Strong Detergents are not recommended, they may contain chemicals like Chloride which react with the Chromium.
- A thin layer of Olive oil on the stainless steel can help protect against Free Carbon and Free Iron Particles in the environment.

Should the Evolution Stainless Steel Camera start to rust:

- Thorough cleaning should remove the rust area, rinse thoroughly. The aim is to remove the area with a low Chromium content and allow the Chromium to reform an oxide.
- Please do not use iron scouring pads or tools to do this.

There are many Stainless Steel cleaners available. Oncam cannot recommend using these as they may react poorly with the polymers in the Dome or Glands compromising either the camera image or the enclosure ingress protection.



Issue 4.0
November 2020